

OKADA

FULL-LINE PRODUCT CATALOG

HYDRAULIC BREAKERS

PLATE COMPACTORS

PULVERIZERS

SHEARS

CRUSHERS

MULTI-PROCESSORS

GRAPPLES

SCREENING BUCKETS





TABLE OF CONTENTS

TOP & ORV SERIES 4-7



HYDRAULIC BREAKERS

OAC SERIES 8-9



PLATE COMPACTORS

OSC SERIES 10-11



FIXED PULVERIZERS

ORC SERIES 12-13



ROTATING PULVERIZERS

OS SERIES 14-15



SCRAP SHEARS

TS-W SERIES 16-17



PRIMARY CRUSHERS

TSRC SERIES 18-19



CRUSHERS & SHEARS

TS-S SERIES 20-21



CRUSHERS & SHEARS

OMS SERIES 22-23



MULTI-PROCESSORS

ORG SERIES 24-25



ROTATING GRAPPLES

OMG SERIES 26



MECHANICAL GRAPPLES

TMB SERIES 27



TROMMEL BUCKETS

Since 1995, OKADA America has been offering a wide variety of hydraulic attachments.

OKADA America operates three warehouses across multiple time zones for optimal parts availability.

All common carrier specific mounting brackets are kept in stock.

Factory reconditioning available for OKADA breakers with factory warranty.

Our PSR's provide hands-on training for dealer technicians at their facilities to enhance performance and ROI.

Our goal is to deliver top-tier products, exceptional customer support, all while maintaining competitive pricing.





TOP SERIES

Advanced OKADA technology eliminates the need for an accumulator without affecting the hydraulic apparatus on the carrier, reducing both maintenance costs and downtime.

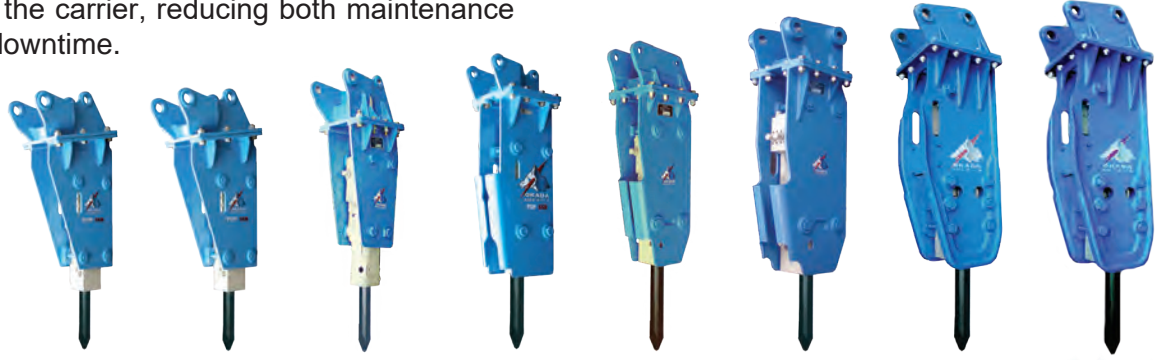

MODELS		TOP31	TOP35B	TOP45C	TOP55B	TOP60CX	TOP90	TOP100A	TOP150
INFORMATION									
Carrier Class	lbs (1000)	3.3 - 8.8	4.4 - 8.8	10 - 18	10 - 18	12 - 20	15 - 26	22 - 42	28 - 42
	m ton	1.5 - 4	2 - 4	4.5 - 8	4.5 - 8	5 - 9	10 - 12	10 - 18	13 - 19
Impact Energy Class	ft lb	375	550	850	1000	1500	1750	2500	3000
	Joules	509	746	1153	1356	2034	2373	3390	4068
Operating Weight	lb	386	565	717	1060	1347	1450	2440	3000
	kg	175	256	325	481	611	658	1107	1361
Unit Working Length	inch	55	61	63	72	81	84	88	94
	cm	140	155	160	183	206	213	224	239
Tool Diameter	inch	2.24	2.4	2.68	2.9	3.35	3.9	4.3	4.8
	mm	57	61	68	74	85	99	109	122
Tool Working Length	inch	14.5	14.6	16.1	19.4	21.2	21.9	23.4	24
	mm	368	371	409	493	538	556	594	610
Frequency	L Model bpm	450 - 1000	380 - 1000	380 - 900	400 - 1100	350 - 700	550 - 850	550 - 710	600 - 750
	S Model bpm	n/a	n/a	n/a	n/a	n/a	n/a	n/a	n/a
ENERGY									
Mechanical Energy	hp	7 - 18	14 - 28	17 - 35	22 - 39	20 - 37	30 - 56	40 - 63	42 - 63
	kW	5.2 - 13.5	11 - 21	13 - 26	17 - 29	15 - 27	23 - 42	30 - 47	31 - 47
Mechanical Energy Average	hp	12.5	21	26	30.5	28.5	43	51.5	52.5
	kW	9	16	19	23	21	32	48	39
HYDRAULICS									
Oil Flow Range	gpm	7 - 15	13-17	14 - 20	15 - 23	16 - 26	22 - 31	29- 35	30 - 35
	lpm	25 - 56	49 - 64	53 - 75	56 - 87	60 - 98	83 - 117	110 - 132	113 - 132
Operating Pressure	psi	1450 - 2030	1600 - 2400	1740 - 2400	2030 - 2465	1990 - 2418	2030 - 2610	2030 - 2610	2030 - 2610
	bar	100 - 140	110 - 165	120 - 165	140 - 170	137 - 167	140 - 180	140 - 180	140 - 180

- 1) Oil flow at no load.
- 2) Specifications are subject to change without prior notice.

BREAKERS

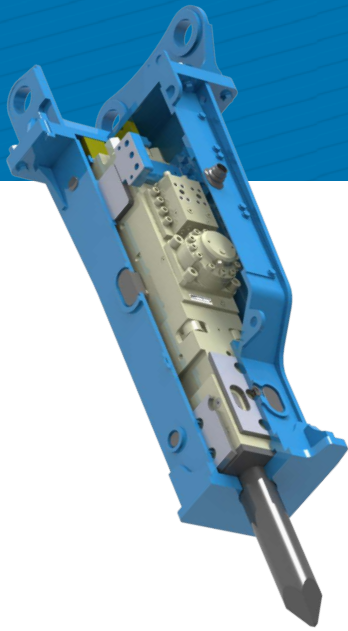

MODELS		TOP205J	TOP270B	TOP300J	TOP350J	TOP400J	TOP800	TOP1000J
INFORMATION								
Carrier Class	lbs (1000)	40 - 57	44 - 66	53 - 79	62 - 99	88 - 132	132 - 176	165 - 265
	m ton	18 - 26	20 - 30	24 - 36	28 - 45	40 - 60	60 - 80	75 - 120
Impact Energy Class	ft lb	4000	5500	7500	9000	12000	15000	17000
	Joules	5424	7458	10170	12204	16272	20340	23052
Operating Weight	lb	3968	5380	5952	6945	9350	12350	15763
	kg	1800	2440	2700	3150	4241	5601	7150
Unit Working Length	inch	103	114	114	126	145	160	177
	cm	262	290	290	320	368	406	450
Tool Diameter	inch	5.3	5.5	5.9	6.1	6.7	7.4	8.3
	mm	135	140	150	155	170	188	210
Tool Working Length	inch	27.5	28.7	32.5	32.6	36.8	40.5	36
	mm	699	730	826	828	935	1029	915
Frequency	L Model bpm	360 - 430	400 - 500	370 - 420	300 - 350	250 - 320	260 - 360	200 - 280
	S Model bpm	500 - 560	600 - 700	450 - 530	n/a	n/a	n/a	n/a
ENERGY								
Mechanical Energy	hp	60 - 95	60 - 105	66 - 113	88 - 130	103 - 167	108 - 182	156 - 219
	kW	45 - 71	45 - 78	49 - 84	66 - 97	77 - 125	80 - 135	116 - 163
Mechanical Energy Average	hp	78	82.5	89.5	109	135	145	188
	kW	58	62	67	81	101	108	140
HYDRAULICS								
Oil Flow Range	gpm	42 - 53	47 - 63	58 - 74	74 - 82	82 - 95	79 - 101	111 - 132
	lpm	159 - 200	178 - 238	220 - 280	280 - 310	310 - 360	300 - 382	420 - 500
Operating Pressure	psi	2030 - 2610	2180 - 2610	2320 - 2465	2320 - 2610	2320 - 2610	1990 - 2610	2610 - 3050
	bar	140 - 180	150 - 180	160 - 170	160 - 180	160 - 180	137 - 180	180 - 210

- 1) The TOP205J, TOP270B and TOP300J models have a two-speed feature. The L- mode frequency is the normal mode.
- 2) Oil flow at no load.
- 3) Specifications are subject to change without prior notice.



ORV SERIES

ORV SERIES HYDRAULIC BREAKERS

ORV Series hydraulic breakers are the result of decades of field experience and OKADA's long-standing record of leadership in the industry.

Thirteen models of ORV hydraulic breakers provide a broad range of solutions for your skid steer loaders, compact excavators, tractor loader backhoes and excavators.



	MODELS	250LT	250H	405H	550H	800SH	1100H	1500HX
INFORMATION								
Carrier Class	1000 lb	2.2 - 5	2.2 - 5	3.3 - 8.8	6.6 - 14.2	10 - 18	10 - 18	13 - 22
	m ton	1 - 2.3	1 - 2.3	1.5 - 4	3 - 6.4	4.5 - 8	4.5 - 8	6 - 10
Impact Energy Class	ft lb	225	225	375	550	850	1100	1500
	Joules	305	305	509	746	1153	1492	2034
Operating Weight	lb	350	321	413	572	780	1118	1667
	kg	159	146	187	259	412	507	756
Unit Working Length	inch	48	48	55	61	63	75	83
	cm	122	122	139	154	161	190	212
Tool Diameter	inch	1.77	1.77	2.24	2.76	2.95	3.15	3.54
	mm	45	45	57	70	75	80	90
Tool Working Length	inch	11.9	11.9	14.1	15.9	16.0	19.5	22.6
	mm	302	302	357	404	406	496	575
Frequency	L Mode bpm	550-1000	550-1000	600-1500	380-1000	380-900	400-800	350-700
	S Mode bpm	n/a	n/a	n/a	n/a	n/a	600-1100	490-1000
ENERGY								
Mechanical Energy	hp	4.5 - 11	4.5 - 11	4.6 - 19	12 - 30	17 - 33	14 - 37	15 - 38
	kW	3.3 - 8	3.3 - 8	3 - 14	9 - 22	13 - 25	10 - 28	11 - 28
Mechanical Energy Average	hp	7.8	7.8	11.8	21	25	25.5	26.5
	kW	6	6	9	16	19	19	20
HYDRAULICS								
Oil Flow Range (At No Load)	gpm	4 - 9	4 - 9	8 - 18	11 - 18	14 - 20	15 - 23	16 - 26
	lpm	15 - 34	15 - 34	30 - 68	42 - 68	53 - 75	56 - 87	60 - 98
Operating Pressure	psi	1280-1706			1564-2437	1706-2347	1990-2418	
	bar	88 - 118			108 - 162	118 - 162	137 - 167	

- 1) All models are Box style housings except the ORV250LT.
- 2) The L- mode frequency is the normal mode.
- 3) Operating weight includes complete breaker assembly with UMB.

BREAKERS



	MODELS	2500H	3000H	4000H	5000HX	7500HX	10000H	12000H
INFORMATION								
Carrier Class	1000 lb	22 - 34	28 - 40	38 - 54	44 - 66	60 - 92	76 - 132	99 - 176
	m ton	10 - 15	13 - 18	17 - 25	20 - 30	27 - 42	35 - 60	45 - 80
Impact Energy Class	ft lb	2500	3000	4000	5000	7500	10000	12500
	Joules	3390	4068	5424	6780	10170	13560	16950
Operating Weight	lb	2289	2883	3646	4573	5925	8636	8965
	kg	1038	1307	1654	2074	2687	3917	3748
Unit Working Length	inch	94	100	103	114	124	141	142
	cm	239	254	262	290	315	358	361
Tool Diameter	inch	4.13	4.53	5.31	5.71	6.10	6.65	7.09
	mm	105	115	135	145	155	170	180
Tool Working Length	inch	23.4	24	28.9	28.2	30.2	34.9	32
	mm	594	610	734	716	767	886	813
Frequency	L Mode bpm	350-550	320-550	320-480	270-400	230-400	230-330	270-380
	S Mode bpm	600-900	400-700	400-600	330-500	270-470	270-500	380-530
ENERGY								
Mechanical Energy	hp	35 - 65	45 - 78	62 - 98	73 - 117	98 - 133	94 - 158	101 - 176
	kW	26 - 48	33 - 58	47 - 73	55 - 87	73 - 99	70 - 117	75 - 131
Mechanical Energy Average	hp	50	61.5	80	95	115.5	126	138.5
	kW	37	46	60	71	86	94	103
HYDRAULICS								
Oil Flow Range (At No Load)	gpm	25 - 35	32 - 42	40 - 53	47 - 63	63 - 72	64 - 85	69 - 95
	lpm	94 - 132	121 - 159	151 - 200	178 - 239	238 - 273	242 - 321	261 - 359
Operating Pressure	psi	1990 - 2700		2275 - 2700			2133 - 2700	
	bar	137 - 180		157 - 180			147 - 187	

- 1) All models are Box style housings except the ORV250LT.
- 2) The L- mode frequency is the normal mode.
- 3) Operating weight includes complete breaker assembly with UMB.



OAC SERIES

OKADA delivers job-cost efficiency and versatility to soil compaction and pile driving with a line of compactors to fit your job-site conditions.

Our Boom-Mounted plate compactors are offered in five sizes to expand the versatility of your backhoe or excavator from 4,000 to 86,000 pounds. Our rugged construction and proven compaction technology make quick work of any compaction or driving task while keeping your crew safely out of the trench, eliminating the need for expensive shoring.

FEATURES

- Full One-Year Warranty on all models.
- Heavy Duty Single Piece formed base plate for extra strength and stability.
- Heavy Duty Rubber Isolators are featured for operator comfort and to maximize energy forces to the compaction plate.
- Standard Flow Control Valve is offered on all models for prevention of overflowing and over-speeding, which also helps ensure extended motor life.
- Custom mounting brackets available to fit most carriers.
- Optional Backfill Blade for compacting trenches which cuts down the need of switching to a bucket. *Available for OAC200 - OAC500.*



Backfill Blade

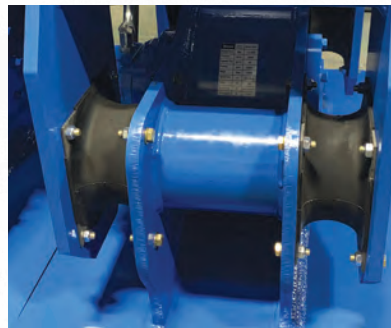

Heavy Duty Rubber Isolators

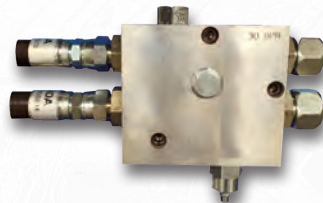

Flow Control Valve

APPLICATIONS

- Aggregate and soil compaction
- Trench compaction
- Steep slope compaction
- Soil stabilization
- Backfilling
- Pile driving -
 - Fence posts
 - Marine work
 - Wood poles for foundations

PLATE COMPACTORS



OAC100
12, 16 & 18" tamper plate width standard sizes



OAC200
Shown with optional Backfill Blade and Swivel



OAC400
Available with optional Backfill Blade



24" wide tamper base plate, suitable for compact utility loaders.



72" wide tamper base plate, suitable for skid steer loaders.



MODELS	CARRIER	WEIGHT	BOTTOM PLATE	FREQUENCY	IMPULSE FORCE	LIFT COMPACTION	OIL FLOW
OAC100	4 - 14,000 lbs 1.8 - 6.4 m tons	500 lb 227 kg	11.5 x 30 in. 292 x 762 mm	2100 cpm	3,150 lbs 1.4 m tons	1 - 3 ft 305 - 914 mm	10 gpm 38 lpm
SSOAC100	4 - 14,000 lbs 1.8 - 6.4 m tons	600 lb 272 kg	21 x 24 in. 533 x 610 mm	2100 cpm	3,150 lbs 1.4 m tons	n/a	10 gpm 38 lpm
OAC150	6 - 12,000 lbs 2.7 - 5.4 m tons	650 lbs 295 kg	16 x 31 in. 406 x 787 mm	2000 cpm	5,500 lbs 2.5 m tons	1.5 - 3.5 ft 457 - 1067 mm	15 gpm 57 lpm
OAC200	12 - 18,000 lbs 5.4 - 8 m tons	850 lb 385 kg	23 x 34 in. 584 x 863 mm	2000 cpm	6,500 lbs 2.9 m tons	2 - 4 ft 610 - 1219 mm	20 gpm 76 lpm
SSOAC200	7 - 12,000 lbs 2.9 - 5.4 m tons	1150 lbs 522 kg	20 x 72 in. 457 x 1829 mm	2000 cpm	6,500 lbs 2.9 m tons	n/a	20 gpm 76 lpm
OAC300-24	20 - 34,000 lbs 9 - 15 m tons	1950 lbs 885 kg	23.7 x 45.4 in. 602 x 1153 mm	2000 cpm	13,500 lbs 6.1 m tons	3 - 5 ft 914 - 1524 mm	30 gpm 114 lpm
OAC300	20 - 40,000 lbs 9 - 18 m tons	1950 lb 885 kg	28 x 44 in. 711 x 1117 mm	2000 cpm	13,500 lbs 6.1 m tons	3 - 5 ft 914 - 1524 mm	30 gpm 114 lpm
OAC400	40 - 56,000 lbs 18 - 25 m tons	2350 lb 1066 kg	34 x 43 in. 863 x 1092 mm	2000 cpm	20,000 lbs 9.1 m tons	5 - 7 ft 1524 - 2134 mm	40 gpm 151 lpm
OAC500	56 - 86,000 lbs 25 - 39 m tons	2500 lb 1134 kg	34 x 43 in. 863 x 1092 mm	2100 cpm	22,000 lbs 10 m tons	5 - 7 ft 1524 - 2134 mm	50 gpm 189 lpm

Optional Backfill Blades add approximately 100-230 lbs to the above listed weights.

SSOAC models are loader mounted compactors only. Operating weight for these models include loader mount bracket.

Bottom plate dimensions are the portion of the plate that contacts the surface ground. *Specifications are subject to change without notice.*

OAC150 and OAC300-24 are for compaction only; use as pile/post drivers or extractors is prohibited.



OSC SERIES

OKADA demolition pulverizers were developed as a result of a growing need to reduce disposal volume and recycle concrete waste created during concrete building demolition. The flat, wide jaw design and an internal speed valve make it possible to grab and crush large sections of concrete quickly.

FEATURES

Grizzly Design (OSC220US)

The pulverizer construction uses a robust, pass-through grizzly design which allows crushed material to easily release from the crushing zone between the jaws.

Bolt-On Replaceable Tooth Pad Models OSC220US & 380A only.

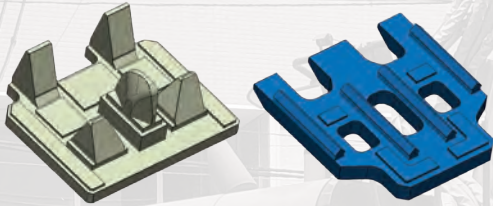

Built-In Pressure Relief Valve

A standard built-in relief valve protects against overload.

Speed Valve for Shorter Cycle Times

A large bore cylinder, short stroke and speed valve creates unmatched crushing force with a short cycle time.

Pulverizing Wedges & Reversible Rebar Cutting Blade

The unique Okada crushing teeth combines pulverizing wedges and cutter blades to efficiently process reinforced concrete.

Protective Structure

The use of a cylinder rod protector and the location of the hydraulic cylinder in the frame protects the cylinder rod from exposure to concrete rubble.

APPLICATIONS

Secondary demolition

- Concrete
- Single-step recycling
- Separating concrete from rebar
- Cuts rebar as needed



see the OSC in action



FIXED PULVERIZERS

SPECIFICATIONS

MODELS		OSC-135B	OSC-220US	OSC-380A	OSC-500A	OSC-200HMA (MAGNETIC)
INFORMATION						
Carrier Class	1000 lb	22 - 35	40 - 66	66 - 110	88 - 220	40 - 66
	ton	10 - 16	18 - 30	30 - 50	40 - 100	18 - 30
Operating Weight	lbs	2800	4823	8700	11280	5316
	kg	1274	2188	3946	5640	2413
Overall Length	inch	77	75	91	116	82
	mm	1955	1905	2318	2950	2075
Overall Height	inch	46	54	67	84	61
	mm	1175	1365	1705	2135	1560
Max. Jaw Opening	inch	29	35	43	58	34
	mm	730	885	1085	1465	870
Cutting Blade Length	inch	6	6	7	9	6
	mm	150	150	180	215	150
FORCE						
Crushing Force at Center	US ton	67	99	108	125	99
	kN	600	880	965	1115	880
HYDRAULICS						
Max. Oil Flow	gpm	53	106	132	198	106
	lpm	200	400	500	700	400
Operating Pressure	psi	4061	4641	4641	4641	4641
	bar	280	320	320	320	320

Specifications are subject to change without notice.

Specifications assume the use of an Okada Universal Pin Mount.

All models are equipped with a speed valve and built-in pressure relief valve.



MAGNET SPECIFICATIONS FOR 200HMA

Magnet Size	inch	27 x 21
	mm	690 x 540
Magnet Lifting	lb	287
	kg	130
Voltage for Magnet	V	24V
Rating Current of Magnet	A	75A





ORC SERIES

OKADA's ORC rotating pulverizers were developed as a result of a growing need to reduce disposal volume and recycle concrete waste created during concrete building demolition. The lat, wide jaw design and an internal speed valve make it possible to grab and crush large sections of concrete quickly.

FEATURES

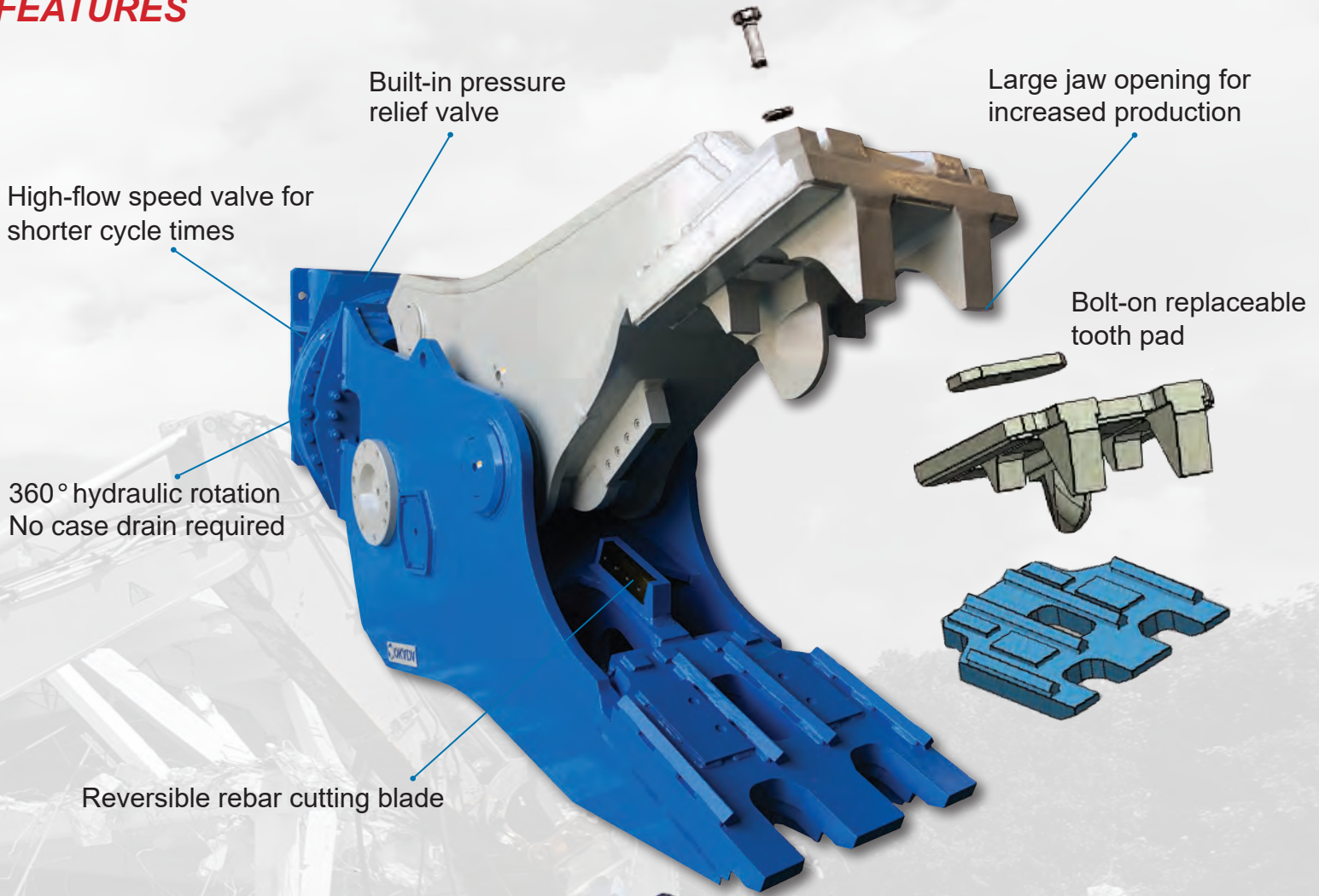

APPLICATIONS

Primary demolition

- Concrete
- Single-step recycling

Secondary demolition

- Separating concrete from rebar
- Cuts rebar as needed

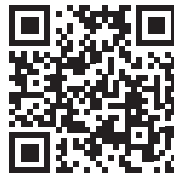

see the ORC in action



ROTATING PULVERIZERS



SPECIFICATIONS

	MODELS	ORC-220A	ORC-380A
INFORMATION			
Carrier Class	1000 lb	48 - 84	71 - 110
	m ton	22 - 38	32 - 50
Operating Weight	lb	5896	9900
	kg	2673	4491
Overall Length	inch	89	111
	mm	2255	2825
Overall Height	inch	48.4	58.9
	mm	1230	1495
Max. Jaw Opening	inch	33	36
	mm	835	915
Cutting Blade Length	inch	7.1	8.5
	mm	180	215
FORCE			
Crushing Force at Center	sh ton	84	125
	kN	750	1110
HYDRAULICS			
Oil Flow Range	gpm	106	132
	lpm	400	500
Operating Pressure	psi	4641	4641
	bar	320	320

Specifications are subject to change without notice.
 Specifications assume the use of an OKADA Universal Pin Mount is used.



OS SERIES

OKADA's OS Series Scrap Shear is a versatile shear made for cutting ferrous and non-ferrous scrap, concrete, pipe, solid round I-beams and plate materials. The OS Shear is perfect for the 13-374,000 lb class carrier which provides flexibility for hard to get to areas of demolition.

FEATURES

Speed Valve reduces opening and closing times, improving productivity

360 degree hydraulic rotation enables precise positioning in high-reach demolition and the double-row thrust bearing ensures high robustness and increased safety



Interchangeable tip and blades make maintenance simple and quick which keeps the tool at full efficiency

Redesigned jaws and increased cutting force allow for high-level performance in metal cutting

(OS1400R Shown)

APPLICATIONS





Primary demolition

- Iron and steel demolition of large structures or buildings, large transport vessels, tanks and cisterns

Secondary demolition

- Scrap and recycling of ferrous material

SCRAP SHEARS

MODELS		140R*	260R	290R	500R	780R	1200R	1400R	2100R	3450R
INFORMATION										
Carrier Class 3rd Member	1000 lb	13 - 20	24 - 28	28 - 37	40 - 55	66 - 88	100 - 121	121 - 143	165 - 187	264 - 374
	m ton	6 - 9	11 - 13	13 - 17	18 - 25	30 - 40	45 - 55	55 - 65	75 - 85	120 - 170
Carrier Class 2nd Member	1000 lb	6.6 - 13	15 - 22	17 - 26	30 - 39	44 - 61	61 - 86	86 - 99	99 - 132	176 - 242
	m ton	3 - 6	7 - 10	8 - 12	14 - 18	20 - 28	28 - 39	39 - 45	45 - 60	80 - 110
Operating Weight 3rd Member	lb	1414	2682	2946	5026	7878	11559	13874	20769	34660
	kg	642	1217	1337	2280	3574	5243	6293	9420	15720
Operating Weight 2nd Member	lb	1582	2921	3185	5176	8472	11949	14994	21499	36620
	kg	718	1326	1446	2348	3843	5420	6801	9751	16609
Overall Length	inch	64	79	83	106	130	144	156	157	189
	mm	1625	2000	2100	2700	3300	3700	3950	3980	4800
Maximum Jaw Opening	inch	10	15	15	18	22	26	30	35	43
	mm	260	375	375	445	565	670	760	900	1100
Jaw Depth	inch	12	16	16	21	25	28	30	35	43
	mm	300	395	395	525	630	720	762	890	1100
JAW OPEN & CLOSE										
Oil Flow	gpm	13 - 26	23 - 29	23 - 29	39 - 52	52 - 66	66 - 79	72 - 99	158 - 185	211 - 264
	lpm	50 - 100	90 - 110	90 - 110	150 - 200	200 - 250	250 - 300	275 - 375	600 - 700	800 - 1000
Operating Pressure	psi	3045 - 4351	3625 - 4351	3625 - 4351	4640 - 5076	4640 - 5076	4640 - 5076	4640 - 5076	4640 - 5511	4640 - 5511
	bar	210 - 300	250 - 300	250 - 300	320 - 350	320 - 350	320 - 350	320 - 350	320 - 380	320 - 380
Speed Valve		--	0	0	0	0	0	0	0	0
ROTATION										
Oil Flow	gpm	2.6 - 7.9	2.6 - 4	7.9 - 10.5	7.9 - 10.5	7.9 - 10.5	7.9 - 10.5	7.9 - 10.5	13.2 - 15.9	15.9 - 19.8
	lpm	10 - 30	10 - 15	30 - 40	30 - 40	30 - 40	30 - 40	30 - 40	50 - 60	60 - 75
Operating Pressure	psi	870 - 3045	2755 - 2900	1305 - 1450	18856 - 2175	1450 - 1667	1450 - 1667	1450 - 1667	2030 - 2175	2755 - 2900
	bar	60 - 210	190 - 200	90 - 100	130 - 150	100 - 115	100 - 115	100 - 115	140 - 150	190 - 200
Case Drain Required (HR)	y / n	1/4" ORFS	no	no	no	1/4" BSPP	1/4" BSPP	1/4" BSPP	1/4" BSPP	1/4" BSPP
CUTTING APPLICATIONS										
Rod 	inch	1.7	2.2	2.2	2.6	3.3	3.9	4.3	5.5	6.5
	mm	42	55	55	65	85	100	110	140	165
Pipe 	inch	5 x 0.16	7 x 0.24	7 x 0.24	8 x 0.31	12.8 x 0.39	16.0 x 0.47	20 x 0.55	24 x 0.63	32 x 0.79
	mm	127 x 4	178 x 6	178 x 6	203 x 8	324 x 10	406 x 12	508 x 14	610 x 16	813 x 20
HEA Beam 	inch	8.0	7.9	7.9	11.0	13.4	15.7	19.7	27.6	31.5
	mm	200	200	200	280	340	400	500	700	800
HEB Beam 	inch	3.9	4.7	4.7	7.9	11.0	11.8	14.2	19.7	25.6
	mm	100	120	120	200	280	300	360	500	650
Plate 	inch	0.20	0.50	0.50	0.60	0.80	1.00	1.00	1.20	1.50
	mm	6	12	12	15	20	25	25	30	38

* OS140R is also available for 3-5 metric ton skid steer loaders (Model SSOS140R).

OKADA America Inc. has a policy of making continuous product improvements and reserves the right to initiate these changes without notice nor obligation.

Operating weight includes Upper Mounting Bracket



TS-W SERIES

OKADA's wide range of TS-W concrete crushers provide the concrete solution for any carrier. Unlike some hydraulic breakers, the TS-W crusher does not emit noise or vibration making it environmentally friendly. Our seamless casting components and custom tooth design create faster material fractioning which is why our TS-W is the crusher of choice.

FEATURES



APPLICATIONS

Primary demolition

- Reinforced concrete constructions
- High-reach demolition
- Foundation demolition
- Single-step recycling

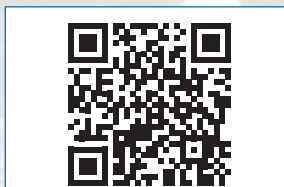

see the TSWB in action



PRIMARY CRUSHERS



SPECIFICATIONS

MODELS		TS-WB 950V	TS-WD 1100V	TS-WD 1400V	TS-WD 1700V	TS-WD 2000V	TS-WD 2200V	TS-WB 2400V
INFORMATION								
Carrier Class	1000 lb	26 - 55	44 - 77	66 - 110	88 - 154	154 - 220	154 - 220	220 -
	m ton	12 - 25	20 - 35	30 - 50	40 - 70	70 - 100	70 - 100	100 -
Operating Weight	lb	4101	5984	9394	11858	17490	23342	28182
	kg	1860	2714	4270	5390	7950	10610	12810
Overall Length	inch	84	97	113	125	139	146	159
	mm	2130	2460	2875	3170	3520	3705	4050
Overall Width	inch	55	64	72	92	106	122	124
	mm	1405	1625	1840	2335	2690	3090	3160
Max. Jaw Opening	inch	37	43	55	67	79	87	95
	mm	950	1100	1400	1700	2000	2200	2400
Cutting Blade Length	inch	6	8	8	10	11	11	11
	mm	150	200	200	250	280	280	280
FORCE								
Crushing Force at Tip	sh ton	68	106	127	154	230	236	242
	kN	605	940	1100	1370	2050	2100	2150
HYDRAULICS								
Max. Oil Flow	gpm	53	106	132	159	185	185	185
	lpm	200	400	500	600	700	700	700
Operating Pressure	psi	4351	4641	4641	4641	4641	4641	4351
	bar	300	320	320	320	320	320	300
Case Drain Required (HR)	y / n	n	n	n	y	y	y	y

All models are equipped with a speed valve and built-in pressure relief valve.

Specifications are subject to change without notice.

Rotation options: Free Rotation (FR) - no hydraulic supply required
 Hydraulic Rotation (HR) - hydraulic supply required from carrier
 OKADA's Advanced Rotation Technology System (ARTS)

Specifications assume the use of an OKADA Universal Pin Mount.



TSRC SERIES

OKADA's wide range of TSRC demolition multi crushers / shears provide the demolition solution for any carrier. Unlike some hydraulic breakers, the TSRC crusher / shear does not emit noise or vibration making it environmentally friendly. Our seamless casting components and custom tooth design create faster material fractioning which is why our TSRC is the crusher / shear of choice.

FEATURES



Seamless casting components

High-pressure twin cylinders

Speed valve for shorter cycle times

Built-in pressure relief valve

360° hydraulic rotation

Reversible main ARC blades
reversible ARC blades decrease contact area which allows for greater cutting power.

APPLICATIONS

Primary demolition

- Rebar
- HEA beam & IPE beam
- Reinforced concrete structures
- High-reach demolition



see the TSRC in action

CRUSHERS & SHEARS



SPECIFICATIONS

MODELS		TSRC 1000V	TSRC 1300V	TSRC 1500V	TSRC 1700V
INFORMATION					
Carrier Class	1000 lb	44 - 77	66 - 110	88 - 154	132 - 220
	m ton	20 - 35	30 - 50	40 - 70	60 - 100
Operating Weight	lb	6086	9636	12480	18566
	kg	2760	4370	5660	8420
Overall Length	inch	101	115	124	143
	mm	2555	2920	3160	3630
Overall Width	inch	61	75	90	96
	mm	1540	1900	2285	2430
Max. Jaw Opening	inch	39	51	59	67
	mm	1000	1300	1500	1700
Cutting Blade Length	inch	18.9	21.7	24	25.6
	mm	480	550	600	650
FORCE					
Cutting Force at Center	sh ton	278	320	409	549
	kN	2470	2850	3640	4880
Crushing Force at Tip	sh tons	107	124	157	208
	kN	950	1100	1400	1850
HYDRAULICS					
Max. Oil Flow	gpm	106	132	159	159
	lpm	400	500	600	600
Operating Pressure	psi	4351	4351	4641	4641
	bar	300	300	320	320
Case Drain Required (HR)	y / n	n	n	y	y



All models are equipped with a speed valve and built-in pressure relief valve.

Rotation options: Free Rotation (FR) - no hydraulic supply required
Hydraulic Rotation (HR) - hydraulic supply required from carrier
OKADA's Advanced Rotation Technology System (ARTS)

Specifications are subject to change without notice.

Specifications assume the use of an OKADA Universal Pin Mount.



TS-S SERIES

OKADA's wide range of TS-S demolition multi crushers / shears provide the demolition solution for a wide range of applications. Unlike some hydraulic breakers, the TS-S crusher / shear does not emit noise or vibration making it environmentally friendly. Our seamless casting components and custom tooth design create faster material fractionation which is why our TS-S is the crusher / shear of choice.

FEATURES



Seamless casting components

Built-in pressure relief valve

360° hydraulic rotation

Single hydraulic cylinder

Reversible main ARC blades
reversible ARC blades decrease contact area which allows for greater cutting power.

Optional cracker tooth



see the TSS in action

APPLICATIONS

Primary demolition

- HEA beam & IPE beam
- Reinforced concrete structures
- Rebar
- High-reach demolition

CRUSHERS & SHEARS



SPECIFICATIONS

	MODELS	TS-S320C	TS-S430C	TS-S550C	TS-S660C
INFORMATION					
Carrier Class	1000 lb	13 - 20	26 - 40	44 - 56	66 - 88
	m ton	6 - 9	12 - 18	20 - 25	30 - 40
Operating Weight	lb	1980	3520	6160	8624
	kg	900	1600	2800	3920
Overall Length	inch	64	86	100	112
	mm	1630	2195	2550	2835
Overall Width	inch	34	44	55	64
	mm	875	1115	1400	1618
Max. Jaw Opening	inch	19	22	27	32
	mm	475	565	690	815
Cutting Blade Length (Frame Side & Arm Side)	inch	13 & 15	17 & 20	22 & 24	26 & 28
	mm	320 & 380	420 & 500	550 & 600	660 & 720
FORCE					
Cutting Force at Center	sh ton	84	121	215	260
	kN	745	1080	1910	2310
HYDRAULICS					
Max. Oil Flow	gpm	16 - 35	26 - 63	44 - 116	66 - 132
	lpm	61 - 132	98 - 238	167 - 439	250 - 500
Operating Pressure	psi	3626	4061	4641	4641
	bar	250	280	320	320
Case Drain Required (HR)	y / n	n	n	n	y

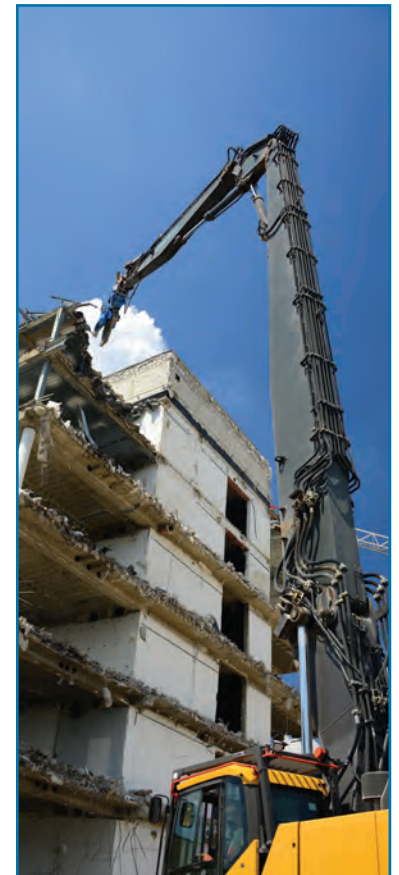

All models are equipped with a built-in pressure relief valve.

Rotation options: Free Rotation (FR) - no hydraulic supply required
 Hydraulic Rotation (HR) - hydraulic supply required from carrier
 OKADA's Advanced Rotation Technology System (ARTS)

Specifications are subject to change without notice.

Specifications assume the use of an OKADA Universal Pin Mount.



OMS SERIES

OKADA's wide range of Multi-Processors and Jaw Kits make them customizable for both primary and secondary demolition, making them the perfect tool for a wide range of specific jobs.

FEATURES

Speed-valve reduces opening and closing times, improving productivity

Continuous hydraulic rotation enables precise positioning in high-reach demolition and the double-row thrust bearing ensures high robustness and increases safety

Inverted cylinders provides the necessary power to face reinforced concrete

Interchangeable jaw sets help make maintenance simple and quick, keeping the tool at full efficiency (see specifications at right for jaw set options)



Quick and easy routine maintenance allows for a reduction in intervention times and costs

Cutting edges can be inserted in the legs allowing the cutting of reinforcement armor. The shear kit cuts scrap and iron structures

APPLICATIONS







Primary demolition

- Reinforced concrete constructions
- High-reach demolition
- Foundation demolition
- Single-step recycling

Secondary demolition

- Concrete
- Cuts rebar as needed
- Separating concrete from rebar
- Single-step recycling

MULTI-PROCESSORS

		<i>MODELS</i>	<i>17R</i>	<i>25R</i>	<i>30R</i>	<i>50R</i>	<i>140R</i>
SPECIFICATIONS							
	Carrier Class	1000 lb	35 - 44	46 - 60	60 - 88	99 - 121	264 - 352
		m ton	16 - 20	21 - 27	28 - 40	45 - 55	120 - 160
	Required Oil Flow	gpm	34 - 40	47 - 58	58 - 66	66 - 79	185 - 264
		lpm	130 - 150	180 - 220	220 - 250	250 - 300	700 - 1000
	Operating Pressure	psi	4640 - 5075	4640 - 5075	4640 - 5075	4640 - 5075	4640 - 5075
		bar	320 - 350	320 - 350	320 - 350	320 - 350	320 - 350
CRUSHER JAW SET							
	Operating Weight	lbs	3640	4875	6395	11200	30865
		kg	1650	2210	2900	5080	14000
	Jaw Opening	inch	29.5	35.0	38.4	47.2	98.4
		mm	750	890	975	1200	2500
	Height	inch	73	78	86	116	169
		mm	1860	1980	2180	2940	4300
PULVERIZER JAW SET							
	Operating Weight	lbs	3750	4960	6880	12020	---
		kg	1700	2250	3120	5450	---
	Jaw Opening	inch	25.6	30.7	34.4	39.4	---
		mm	650	780	875	1000	---
	Height	inch	72	77	86	113	---
		mm	1830	1955	2180	2870	---
SCRAP SHEAR JAW SET							
	Operating Weight	lbs	3750	4930	6505	10870	30865
		kg	1700	2200	2950	4930	14000
	Jaw Opening	inch	13.0	18.1	21.7	24.8	45.3
		mm	330	460	550	630	1150
	Height	inch	71	79	86	116	163
		mm	1800	1995	2185	2945	4150
COMBI-CUTTER JAW SET							
	Operating Weight	lbs	3750	4930	6615	11640	---
		kg	1700	2235	3000	5280	---
	Jaw Opening	inch	27.6	32.7	34.4	43.3	---
		mm	700	830	875	1100	---
	Height	inch	73	80	85	120	---
		mm	1860	2020	2170	3040	---
PLATE SHEAR JAW SET							
	Operating Weight	lbs	---	4565	5955	9480	---
		kg	---	2070	2700	4300	---
	Jaw Opening	inch	---	11.8	12.2	14.2	---
		mm	---	300	310	360	---
	Height	inch	---	75	79	109	---
		mm	---	1895	2000	2760	---

OKADA America Inc. has a policy of making continuous product improvements and reserves the right to initiate these changes without notice nor obligation. Operating weight includes a jaw set with Upper Mounting Bracket



ORG SERIES

The OKADA HD Rotating Grapple, is an indispensable piece of equipment designed to tackle the diverse demands of construction and demolition sites with unparalleled efficiency and precision. With its robust design and advanced features, the OKADA HD Rotating Grapple effortlessly performs tasks ranging from material handling and demolition to sorting, clearing debris, site preparation, and loading/unloading operations. Engineered to excel in even the most demanding environments, this grapple revolutionizes workflows, making every job easier and more streamlined.

FEATURES

Quick maintenance

Heavy-duty and robust design

Load Control Valve
(The hydraulic cylinders are fitted with a load control valve which protects against unexpected opening of the shells)

360 degree rotation

Replaceable teeth / blades

APPLICATIONS

Primary

- Material Handling
concrete • steel • wood • debris • other construction material
- Demolition of structures
breaks apart concrete and the dismantling of large structures.
- Sorting and separating
materials for recycling and disposal
- Clearing debris and waste from jobsites
- Site preparation

ROTATING GRAPPLES

SPECIFICATIONS

MODELS		8R-HD	14R-HD	18R-HD	23R-HD	32R-HD	40R-HD	47R-HD	51R-HD	57R-HD	64R-HD	81R-HD
INFORMATION												
Carrier Class	1000 lb	6.6 - 13	11 - 17	15 - 24	24 - 33	30 - 39	39 - 48	46 - 55	55 - 66	66 - 77	77 - 88	88 - 110
	m ton	3 - 6	5 - 8	7 - 11	10 - 15	14 - 18	18 - 22	21 - 25	25 - 30	30 - 35	35 - 40	40 - 50
Operating Weight	lbs	829	1359	1828	2277	3156	3487	3685	5118	5692	6377	8068
	kg	377	617	830	1034	1432	1582	1672	2322	2582	2893	3660
Volume	ft ³	3.5	7.1	10.6	14.1	17.7	24.7	28.3	31.8	35.3	38.8	47.7
	L	100	200	300	400	500	700	800	900	1000	1100	1350
DIMENSIONS												
Dimension A	inch	43	59	65	67	79	79	83	88	88	88	97
	mm	1100	1500	1650	1700	2000	2000	2100	2230	2240	2240	2450
Dimension B	inch	28	41	43	43	51	51	56	55	56	57	62
	mm	715	1030	1090	1100	1300	1300	1430	1400	1420	1455	1578
Dimension C	inch	32	43	45	45	53	53	54	59	59	59	62
	mm	800	1100	1130	1140	1340	1340	1370	1490	1500	1500	1565
Dimension D	inch	36	49	52	53	61	61	63	69	70	70	73
	mm	910	1240	1310	1340	1550	1550	1600	1745	1770	1770	1854
Dimension L	inch	20	24	24	32	30	39	39	47	51	53	59
	mm	500	600	600	800	750	1000	1000	1200	1300	1350	1500
HYDRAULICS												
Oil Flow	gpm	2.6 - 3.9	5.2 - 7.9	5.2 - 7.9	5.2 - 7.9	13.2 - 15.8	13.2 - 15.8	13.2 - 15.8	18.4 - 21.1	18.4 - 21.1	18.4 - 21.1	26.4 - 31.7
	lpm	10 - 15	20 - 30	20 - 30	20 - 30	50 - 60	50 - 60	50 - 60	70 - 80	70 - 80	70 - 80	100 - 120
Working Pressure	psi	2900 - 3625	2900 - 3625	3625 - 4350	4350 - 4640	4350 - 5075	4350 - 5075	4350 - 5075	4350 - 5075	4350 - 5075	4350 - 5075	4350 - 5075
	bar	200 - 250	200 - 250	250 - 300	300 - 320	300 - 350	300 - 350	300 - 350	300 - 350	300 - 350	300 - 350	300 - 350

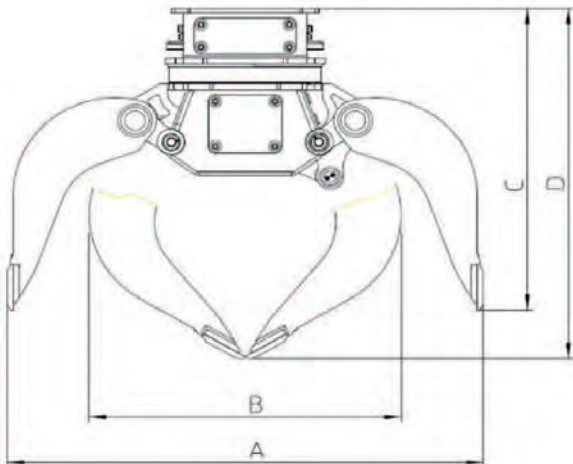

OKADA America Inc. has a policy of making continuous product improvements and reserves the right to initiate these changes without notice nor obligation.

Operating weight includes Upper Mounting Bracket



OMG MECHANICAL GRAPPLES

The OKADA Mechanical Grapples is the ideal excavator attachment for land clearance, skip sorting and general forestry work. The mechanical grapple is the premier grapple of choice in the demolition and forestry industries due to its robust design and ease of use.

As our grapples are designed for use directly in place of the machines own bucket, no additional circuitry or hydraulics are required for the grapple as it uses the excavator link arm and cylinder to create movement. As the bucket cylinder is opened or closed, the jaws are opened or closed to grab carry or load.

The HD finger design allows for better handling of materials and more flexibility. The interlocked webbed design also provides more strength through the grapple construction. Built to exact tolerances from premium materials, the OKADA Mechanical Grapples have an excellent strength to weight ratio. The robust, high strength steel reduces maintenance costs and increases lateral strength and longevity.

KEY FEATURES

- HD Interlocked webbed design gives maximum strength
- Replaceable bearings in main hinges
- High strength, anti-abrasion steel
- Complies with rigorous safety requirements
- Seals protect the pins from

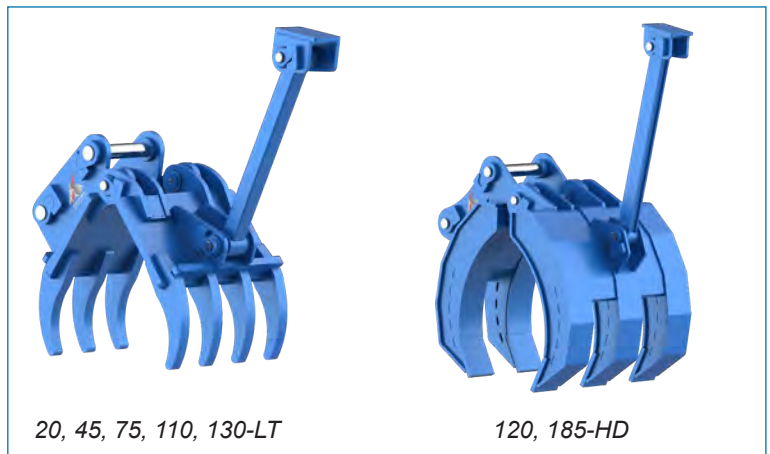

APPLICATIONS

The OKADA Mechanical Grapple has been the grapple of choice in the demolition and logging industry for many years due to its robustness and simplicity. Their ability to handle irregularly shaped loads and loose materials makes them an essential tool or reprocessing, sorting and demolition works.

SPECIFICATIONS

MODELS		20-LT Standard	45-LT Standard	75-LT Standard	110-LT Standard	130-LT Standard	120-HD Heavy Duty	185-HD Heavy Duty
INFORMATION								
Carrier Class	1000 lb	2.2 - 6.6	6.6 - 13	13 - 20	20 - 28	25 - 34	22 - 31	34 - 48
	m ton	1 - 3	3 - 6	6 - 9	9 - 13	11 - 15	10 - 14	15 - 22
Operating Weight	lb	143	276	496	1102	1653	1422	2535
	kg	65	125	225	500	750	645	1150
Functional Jaw Opening	inch	31.5	39.4	47.2	62.2	67.3	74.0	84.6
	mm	800	1000	1200	1580	1710	1880	2150
Front Jaw Width	inch	9.8	12.2	13.8	19.7	22.4	20.9	25.6
	mm	250	310	350	500	570	530	650
Rear Jaw Width	inch	14.2	17.3	19.7	27.6	32.5	35.0	43.3
	mm	360	440	500	700	825	890	1100
Tine Jaw Arrangement		3 & 4	3 & 4	3 & 4	3 & 4	3 & 4	2 & 3	2 & 3

OKADA America Inc. has a policy of making continuous product improvements and reserves the right to initiate these changes without notice nor obligation.

TMB SCREENING BUCKETS



SCREENING PRODUCTIVITY

SCREEN SIZE

MODELS	100 mm 4 in.	60 mm 2-2/8 in.	50 mm 2 in.	40 mm 1-9/16 in.	30 mm 1-3/16 in.	20 mm 3/4 in.	10 mm 3/8 in.
TMB-50	34.4 yd ³ /h	24.6 yd ³ /h	22.4 yd ³ /h	19.5 yd ³ /h	16.4 yd ³ /h	12.9 yd ³ /h	8.6 yd ³ /h
TMB-70	42.1 yd ³ /h	30.1 yd ³ /h	27.3 yd ³ /h	23.8 yd ³ /h	20.0 yd ³ /h	15.8 yd ³ /h	10.5 yd ³ /h

The numbers above do not assure productivity and vary depending on the operation, machine condition and material being screened.

SPECIFICATIONS

MODELS	CARRIER	WEIGHT	OVERALL DIMENSIONS	SCREEN DIAMETER	SCREEN LENGTH	SCREEN DRUM CAPACITY	RPM
TMB-50	20 - 38,000 lbs 9.1 - 17 m tons	2,650 lb 1202 kg	93.3 L x 55.9 W in. 237 x 142 mm	43.3 in. 110 mm	49.2 in. 125 mm	1.6 yd ³ 1.2 m ³	25
TMB-70	40 - 60,000 lbs 18 - 27 m tons	4,900 lb 2222 kg	100.8 L x 63.4 W in. 256 x 161 mm	47.2 in. 120 mm	55.1 in. 140 mm	2.1 yd ³ 1.6 m ³	25

Specifications are subject to change without notice.

Your Local OKADA Dealer



HYDRAULIC BREAKERS | PLATE COMPACTORS
DEMOLITION CRUSHERS & SHEARS | PULVERIZERS
MULTI-PROCESSORS | TROMMEL SCREENING BUCKETS
DEMOLITION & MATERIAL GRAPPLES

COUNT ON OKADA.

WWW.OKADAAMERICA.COM



OREGON

372 S SEQUOIA PKWY
CANBY, OR 97013

503.557.7033 | F 503.557.7779

OHIO

904 MEDINA RD.
MEDINA, OH 44256

330.239.2666 | F 330.239.3670

TEXAS

3575 WINDMILL RD. BLDG #2
JOSHUA, TX 76058

